

>12-13

School Folder Catalog

| | |
|--------------------------------------|----|
| Standard Folder | 2 |
| Handbook Folder | 3 |
| Full-Color Stock Covers | 4 |
| NEW Substitute Teacher Folder | 5 |
| Custom Cover Designs | 6 |
| Back Cover Designs | 7 |
| Options | 8 |
| Order Form | 11 |

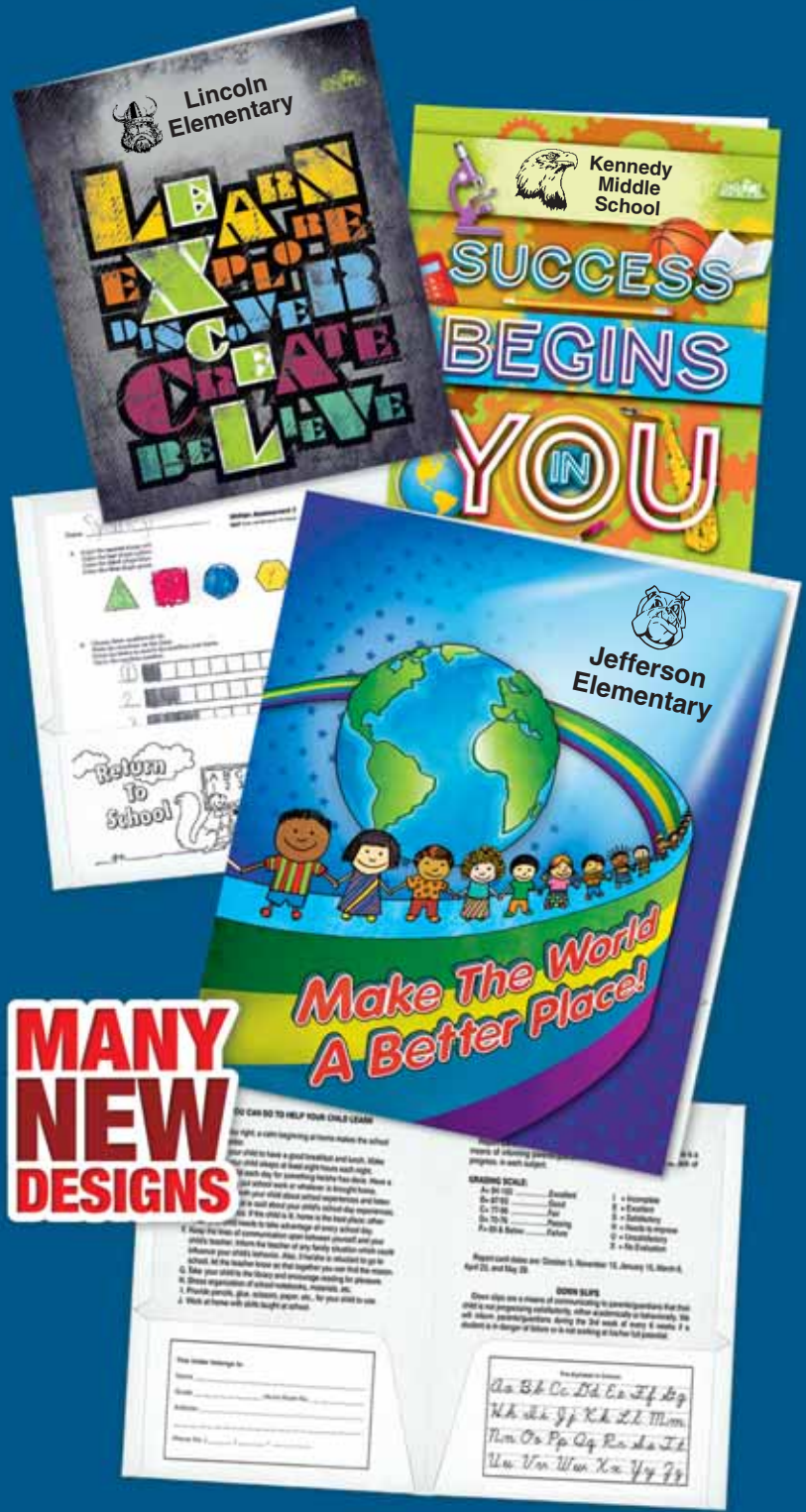

MANY NEW DESIGNS

Keep your students organized with School Mate® folders!

Standard Folder

Standard Folder Features

- 100 minimum order.
- **Front Cover** – Choose a full-color stock cover design or a one- or two-color custom cover design (p. 4–6).
- **Back Cover** – Choose a stock cover design (p. 7) or provide custom material.
- **Pocket Printing** – Choose a stock design (p. 8) or provide custom material.
- For guidelines on submitting custom material, see p. 9.

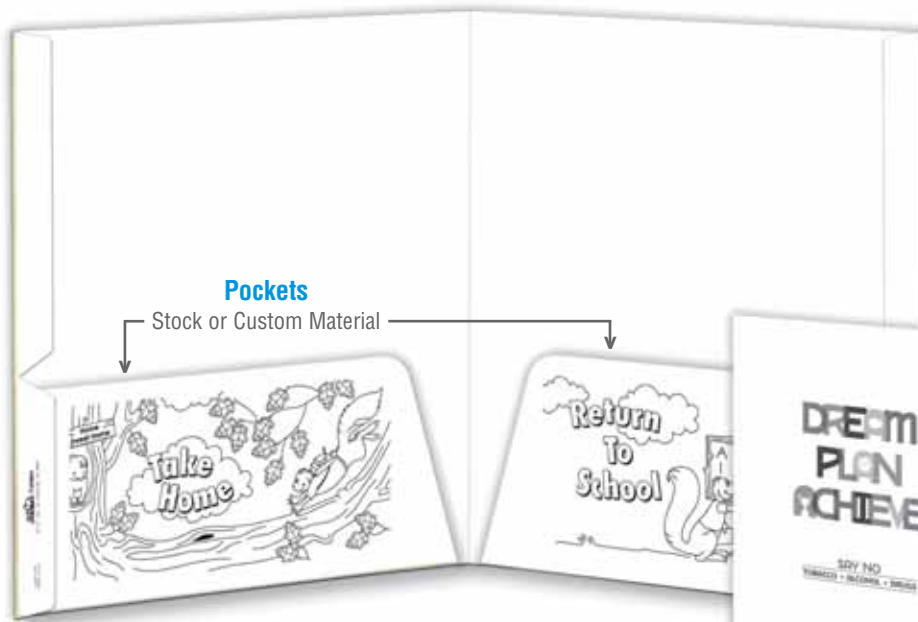

- 9 1/2" x 11 5/8" size
- 8 1/2" x 11" capacity
- 4 1/2" deep pockets
- 3-hole drilled – optional for **no extra charge**
- Sturdy, double-reinforced sides and pockets

Standard Folders include printing on the entire folder except the area above the pockets.

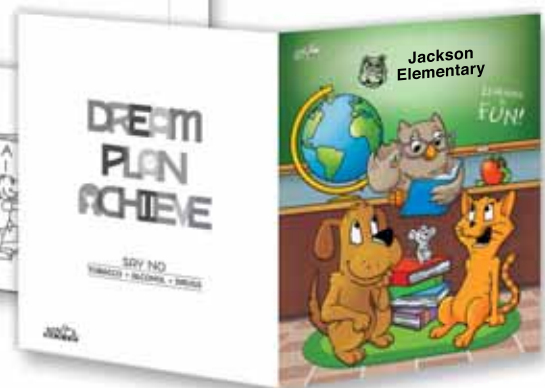

Front & Back Covers
Stock or Custom Material

Standard Folder Prices* **FREE SHIPPING**

| QUANTITY | 100 | 200 | 300 | 400 | 500 | 600 | 700 | 800 | 900 | 1000 | 1100 | 1200 | 1300 | 1400 | 1500 | 2000 | 3000 | 4000 | 5000 |
|----------------------------------|------|------|------|------|------|------|-----|-----|-----|------|------|------|------|------|------|------|------|------|------|
| Full-Color Stock Design (p. 4-5) | 1.94 | 1.22 | 1.00 | .91 | .83 | .81 | .80 | .79 | .78 | .77 | .76 | .75 | .74 | .73 | .71 | .67 | .66 | .64 | .63 |
| One-Color Design (p. 6) | 2.04 | 1.28 | 1.02 | .92 | .84 | .79 | .76 | .74 | .73 | .72 | .71 | .70 | .69 | .68 | .66 | .65 | .62 | .60 | .59 |
| Two-Color Design (p. 6) | 3.11 | 1.83 | 1.41 | 1.21 | 1.08 | 1.00 | .96 | .93 | .88 | .86 | .84 | .82 | .80 | .79 | .74 | .70 | .67 | .65 | .65 |

*Prices shown indicate price per folder with identical printing.

Prices Include:

- 21 full-color stock cover designs available (imprinted with mascot and wording of your choice) – p. 4–5
- One- or two-color cover designs available – p. 6
- Back cover printing – p. 7
- Pocket printing – p. 8

Plus all these **FREE** extras:

- **FREE** protective UV coating on front and back covers
- **FREE** shipping within the continental USA
- **FREE** typesetting for text (English only)
- **FREE** 15 pt. heavy cover stock
- **FREE** folder proof for approval

Order online at www.schoolmate.com

or see p. 11 for the order form.

Handbook Folder



Handbook Folder Features

EXACTLY THE SAME AS THE STANDARD FOLDER, PLUS:

Handbook Printing – area directly above pockets can be printed with custom material (e.g., student handbook, rules of conduct, course descriptions, school calendar, etc.). See p. 9 for details.

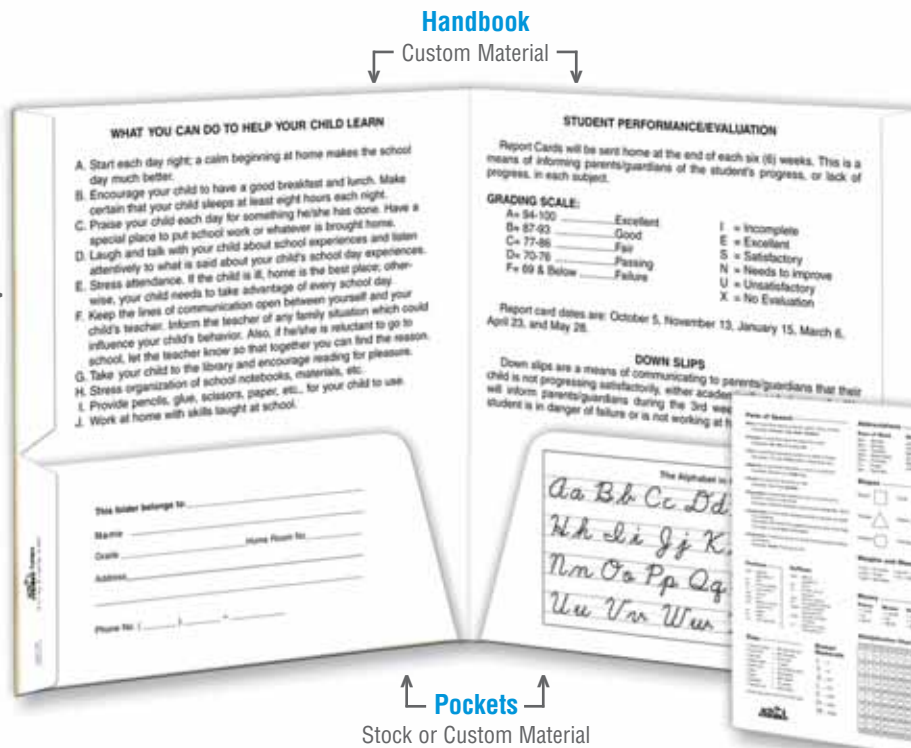

- 9 1/2" x 11 5/8" size
- 8 1/2" x 11" capacity
- 4 1/2" deep pockets
- 3-hole drilled – optional for **no extra charge**
- Sturdy, double-reinforced sides and pockets

Handbook Folders include printing on the entire folder.

Front & Back Covers
Stock or Custom Material

Handbook Folder Prices* **FREE SHIPPING**

| QUANTITY | 100 | 200 | 300 | 400 | 500 | 600 | 700 | 800 | 900 | 1000 | 1100 | 1200 | 1300 | 1400 | 1500 | 2000 | 3000 | 4000 | 5000 |
|----------------------------------|------|------|------|------|------|------|------|------|------|------|------|------|------|------|------|------|------|------|------|
| Full-Color Stock Design (p. 4-5) | 3.82 | 2.18 | 1.66 | 1.42 | 1.25 | 1.17 | 1.13 | 1.09 | 1.06 | 1.03 | 1.00 | .97 | .95 | .93 | .89 | .81 | .77 | .74 | .72 |
| One-Color Design (p. 6) | 3.92 | 2.24 | 1.68 | 1.43 | 1.26 | 1.15 | 1.09 | 1.04 | 1.01 | .98 | .95 | .92 | .90 | .88 | .84 | .79 | .73 | .70 | .68 |
| Two-Color Design (p. 6) | 4.99 | 2.79 | 2.07 | 1.72 | 1.50 | 1.36 | 1.29 | 1.23 | 1.16 | 1.12 | 1.08 | 1.04 | 1.01 | .99 | .95 | .88 | .81 | .77 | .74 |

*Prices shown indicate price per folder with identical printing.

Prices Include:

- **ALL** the features and extras of a Standard Folder, **plus Handbook Printing** – the area directly above the pockets

Make the Right Choice...

Which folder style should you order? To help you decide, first assess your needs. Will your students need custom material, such as a student handbook, rules of conduct, course descriptions, or a school calendar? If so, the Handbook Folder is the perfect choice for you. You can print on the entire folder.

Order online at www.schoolmate.com

or see p. 11 for the order form.

Call **800-516-8339**

Full-Color Stock Covers

- **Imprint your wording and school mascot** in black ink. Provide a clear copy of your school mascot or select from our mascot library at www.schoolmate.com.
- All folders include **FREE** protective UV coating to enhance colors and make folders resistant to spills.

- Choose linen-finish **plastic lamination** for only **20¢/folder**. This super-strong plastic provides longer-lasting durability that resists stains, spills, fingerprints, and scratches and makes folders less likely to tear.
- To allow for writing, pockets will **NOT** be plastic laminated.



All full-color stock designs are preprinted and cannot be changed except to add your mascot and wording.

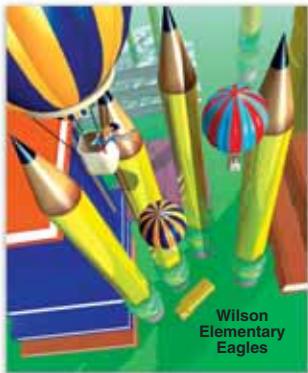

F06

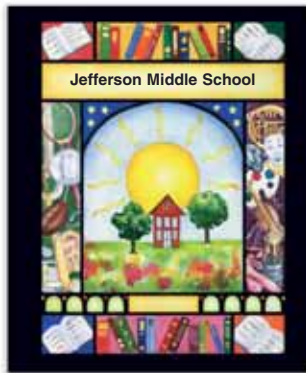

F10

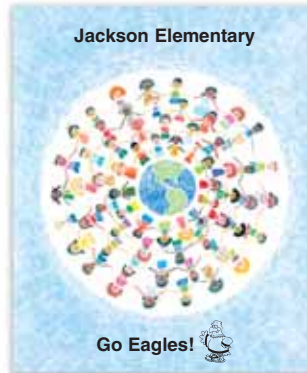

F21

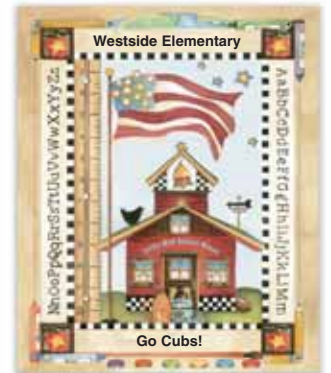

F22



F23

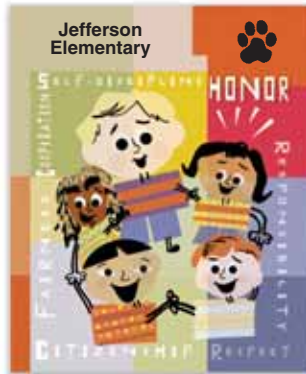

F29

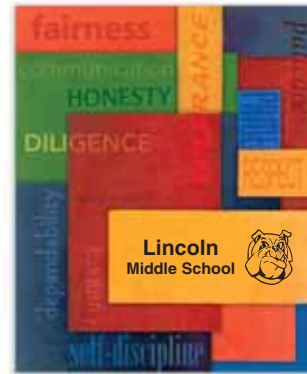

F37

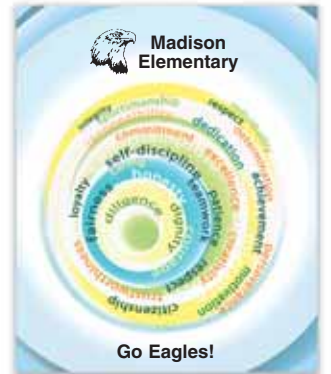

F41

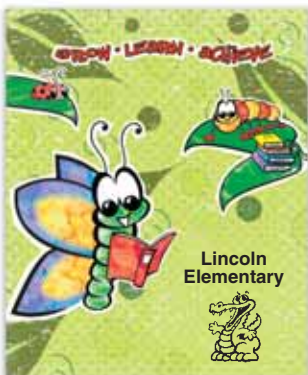

F42



F43

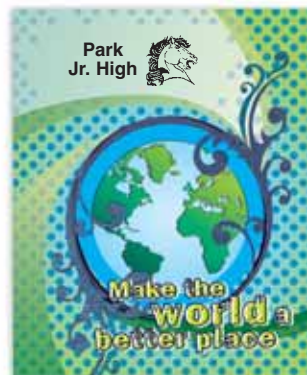

F44

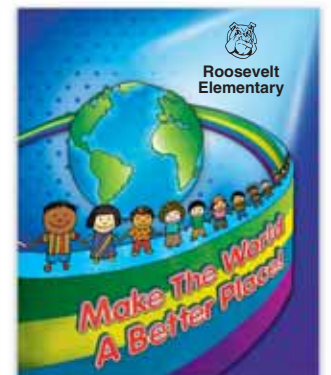

F48



F49

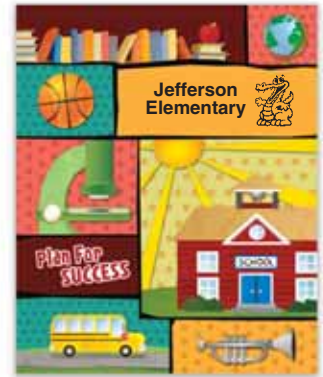

F50



F51



F52

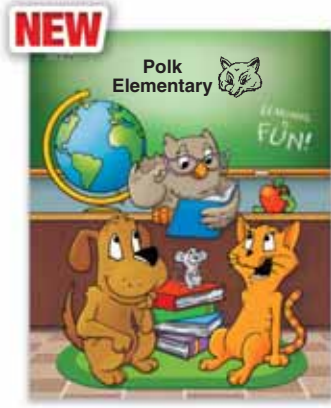

F53

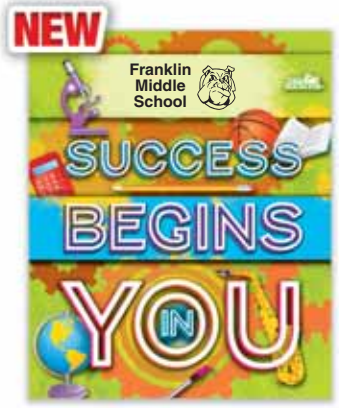

F54

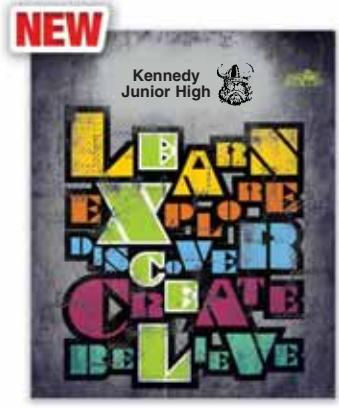

F55

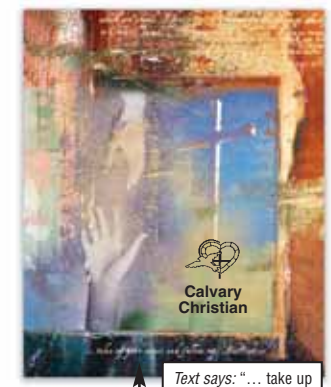

FR3 Religious Design
Text says: "... take up your cross and follow me." Matt. 16:24

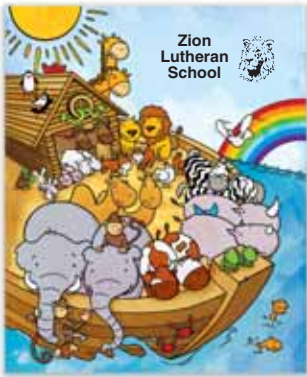

FR4 Religious Design

NEW Substitute Teacher Folder – ST1

Our **NEW** Substitute Teacher Folder will help make the job easier and give classroom teachers all the info they need right at their fingertips. This convenient writable folder includes space for:

- classroom schedules and school day info
- school and emergency procedures
- support staff and key personnel
- areas for notes and classroom duties
- locations of classroom supplies
- checklist for folder contents

Note:

- To allow for writing, the folder will not be UV coated or plastic laminated.
- Folders cannot be customized.
- If Substitute Teacher Folders are ordered separately, they will ship in 5–10 business days. Otherwise, folders will ship together with your Standard or Handbook Folder order.
- Minimum order is 25. Shipping is **FREE**.

| QUANTITY | 25 | 50 | 75 | 100 | 200 | 300 | 500 | 1000 |
|----------|------|-----|-----|-----|-----|-----|-----|------|
| ST1 | 1.30 | .90 | .80 | .73 | .67 | .64 | .60 | .55 |

VIEW LARGER VERSIONS ONLINE



ST1 – Showing Front & Back Cover



ST1 – Showing Inside

Custom Cover Designs

Create a custom cover one of two ways:

1. Use a School Mate® design printed in your school color(s) with your mascot and wording. See inks below.
2. Submit your own custom design. For Custom Guidelines, see p. 9.

All covers include **FREE** protective UV coating, or use super-durable plastic lamination for only **20¢/folder**.

One-Color Designs



CF15



CF16



CF17

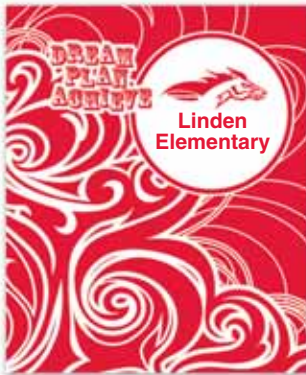

CF18



CF19

Two-Color Designs



TF15

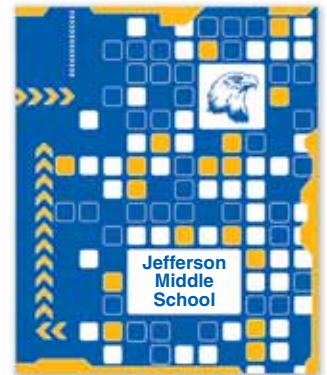

TF16

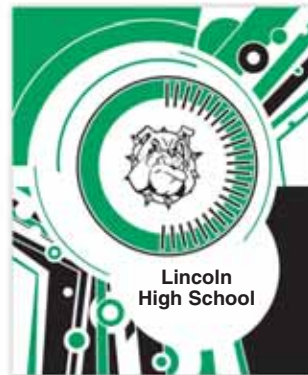

TF17

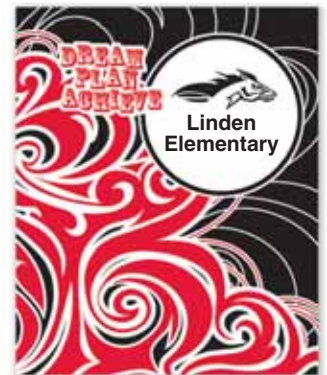

TF18

Standard Inks

- Use any standard ink(s) on your custom cover.
- Printed on white cover stock.

Due to the printing process, colors shown may vary from actual printed colors. Printed cover colors can also vary from year to year.

| | | | | | | | |
|-------------------|------------------|---------------|---------------|-------------|--------------|----------------|------------------|
| | | | | | | | |
| 116 Light Gold | 1235 Old Gold | 021 Orange | 527 Purple | 281 Navy | 286 Royal | PBL Process | 321 Turquoise |
| | | | | | | | |
| 347 Green | 554 Hunter | 469 Brown | 186 Red | 202 Wine | 421 Smoke | BK Black | |



TF19

Back Cover Designs



Back Cover Printing

- Includes **FREE** protective UV coating, or use super-durable plastic lamination for only **20¢/folder**.
- Printed in black ink if using a full-color cover stock design.
- Printed in one ink (same as chosen for a custom cover; darkest ink if using two inks).
- Use a stock design or submit custom material (e.g., school map or activities calendar). For Custom Guidelines, see p. 9.
- Design charges may apply for complex material (e.g., maps, calendars, charts) that needs to be recreated.

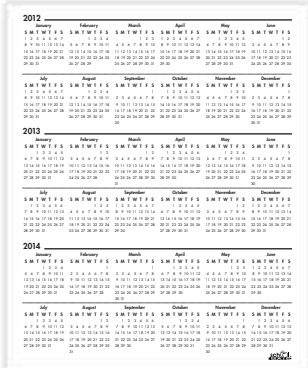

B1
3-Year Calendar
2012–2014

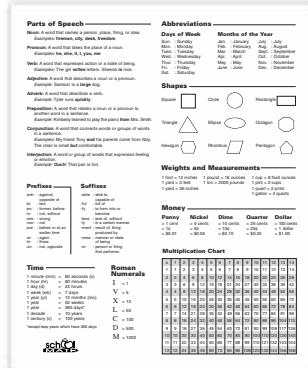

B4
Reference Design
Suggested for elementary only.

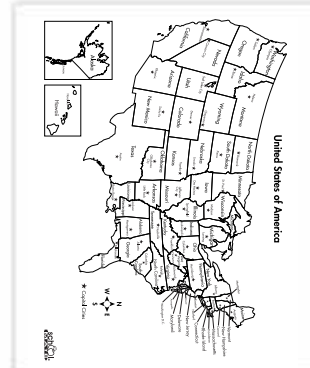

B7
USA Map
Shows all 50 states and capitals.

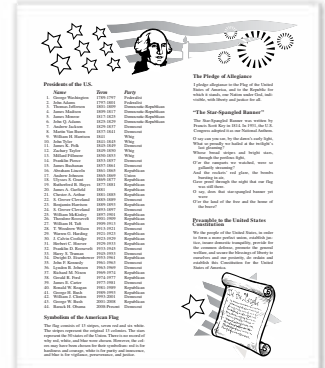

B8
Patriotic Design
Lists presidents, the Pledge of Allegiance, "The Star-Spangled Banner," and the Preamble to the United States Constitution.

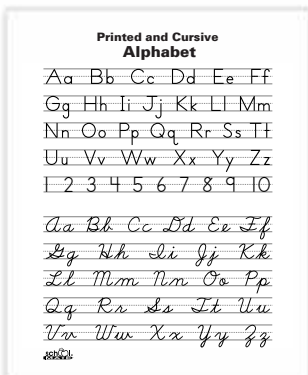

B13
Printed & Cursive Alphabet
Shows entire alphabet and numbers (1–10) in printed and cursive forms.



B14
Dream, Plan, Achieve™
"Say No – Tobacco, Alcohol, Drugs"

**VIEW
LARGER
VERSIONS
ONLINE**

Submitting Mascots & Artwork

- Tip 1:** Submit a clear, sharp copy of your school mascot. **Do NOT fax it.**
- Tip 2:** Artwork **MUST** be black line drawings on white paper. Artwork with gray shading, pencil, marker, or crayon drawings does not print well.
- Tip 3:** Submit artwork as close to desired size as possible. Reducing may result in loss of quality and enlarging may magnify imperfections.
- Tip 4:** Do not submit artwork from photocopies or newspaper copy, as this material does not print well.
- Tip 5:** Send artwork flat, protected with heavy cardboard.

YES
Line Art



NO
Shades
Screens
Gradients
Color



For your convenience, visit our online mascot library at www.schoolmate.com

If this material is submitted, School Mate® is not responsible for poor print quality.

Printing Options

3-Hole Drill

- Folders may be 3-hole drilled for **no extra charge**.
- Indicate this option on the order form. If no selection is made, folders will not be drilled.

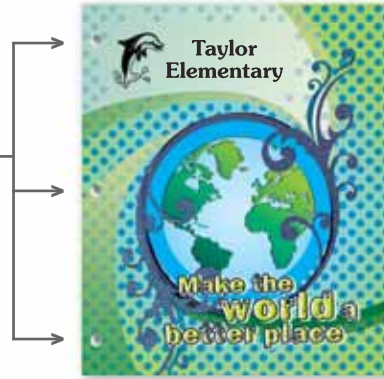

Pocket Printing

- Included in all folder base prices.
- Printed in black ink if using a full-color stock cover design.
- Printed in one ink (same as chosen for a custom cover; darkest ink if using two inks).
- Use stock designs or submit custom material (p. 9).

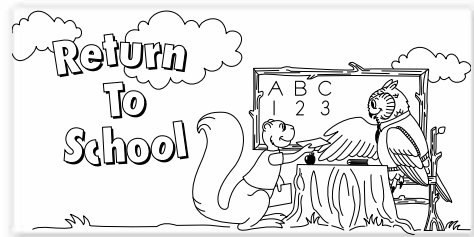

P4

Multiplication Table

| | 1 | 2 | 3 | 4 | 5 | 6 | 7 | 8 | 9 | 10 | 11 | 12 |
|----|----|----|----|----|----|----|----|----|-----|-----|-----|-----|
| 1 | 1 | 2 | 3 | 4 | 5 | 6 | 7 | 8 | 9 | 10 | 11 | 12 |
| 2 | 2 | 4 | 6 | 8 | 10 | 12 | 14 | 16 | 18 | 20 | 22 | 24 |
| 3 | 3 | 6 | 9 | 12 | 15 | 18 | 21 | 24 | 27 | 30 | 33 | 36 |
| 4 | 4 | 8 | 12 | 16 | 20 | 24 | 28 | 32 | 36 | 40 | 44 | 48 |
| 5 | 5 | 10 | 15 | 20 | 25 | 30 | 35 | 40 | 45 | 50 | 55 | 60 |
| 6 | 6 | 12 | 18 | 24 | 30 | 36 | 42 | 48 | 54 | 60 | 66 | 72 |
| 7 | 7 | 14 | 21 | 28 | 35 | 42 | 49 | 56 | 63 | 70 | 77 | 84 |
| 8 | 8 | 16 | 24 | 32 | 40 | 48 | 56 | 64 | 72 | 80 | 88 | 96 |
| 9 | 9 | 18 | 27 | 36 | 45 | 54 | 63 | 72 | 81 | 90 | 99 | 108 |
| 10 | 10 | 20 | 30 | 40 | 50 | 60 | 70 | 80 | 90 | 100 | 110 | 120 |
| 11 | 11 | 22 | 33 | 44 | 55 | 66 | 77 | 88 | 99 | 110 | 121 | 132 |
| 12 | 12 | 24 | 36 | 48 | 60 | 72 | 84 | 96 | 108 | 120 | 132 | 144 |

P1



P5

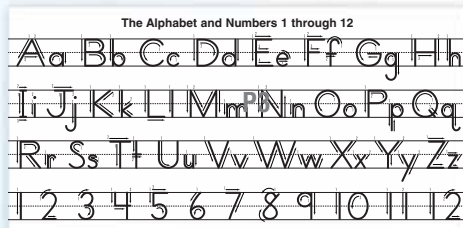

P2

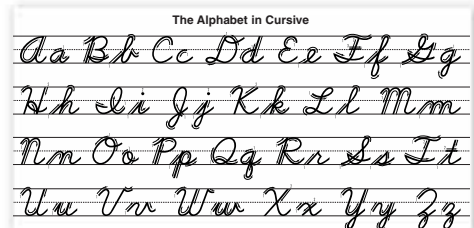

P8

This folder belongs to:

Name _____

Grade _____ Home Room No. _____

Address _____

Phone No. (____) _____ - _____

P3

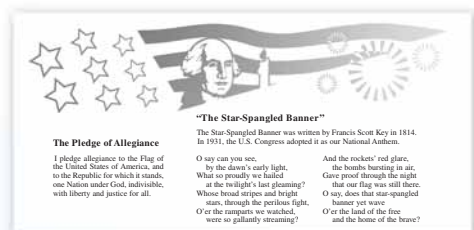

P9

Custom Material



Handbook Printing

Handbook Printing (area above pockets)

- Available for **HANDBOOK FOLDERS ONLY**.
- Included in handbook folder base prices.
- Printed in black ink if using a full-color stock cover design.
- Printed in one ink (same as chosen for a custom cover; darkest ink if using two inks).
- For guidelines and a template, see below.

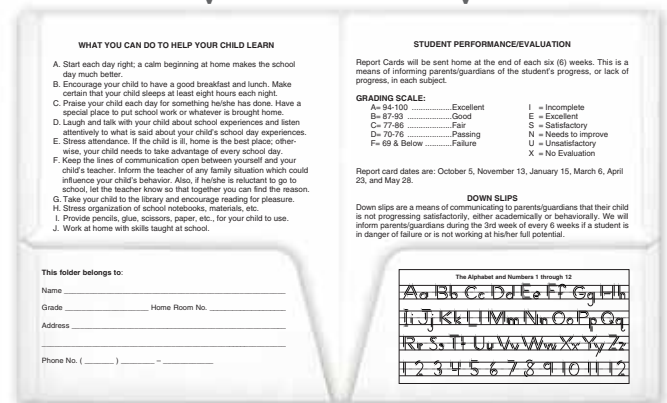

Pocket Printing

Custom Guidelines

Press-Ready Material Submitted By You

Text and artwork must fit within the yellow areas indicated on the templates below. This material should be set in type with no alterations. Your pages are ready to print as is. Therefore, submit clear, sharp artwork and text. To ensure accurate sizes and margins, use our Microsoft® Word Templates from the Download Center of our web site. Digital files **MUST** be sent via our web site. **Do NOT fax artwork or press-ready material.**

- If sending a digital file: Submit ALL file types using our **Electronic File Submission Tool**, as this process will embed fonts and upload your file to School Mate®. **Fonts MUST be embedded.** We prefer all files sent via our web site, www.schoolmate.com. Click on the "Submit Material" button for instructions.
- If mailing a hard copy: Mail laser printed pages on white paper, printed on only one side. **DO NOT FAX** pages.

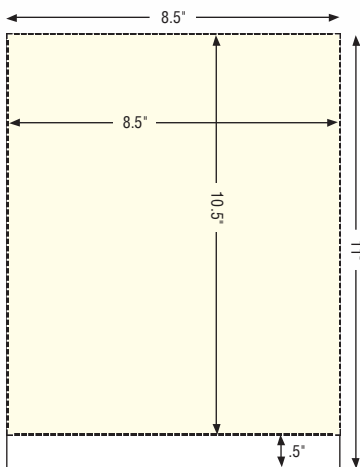

Front & Back Covers

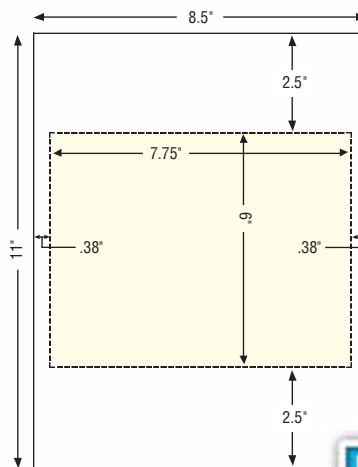

Folder Handbook
(area above pockets)

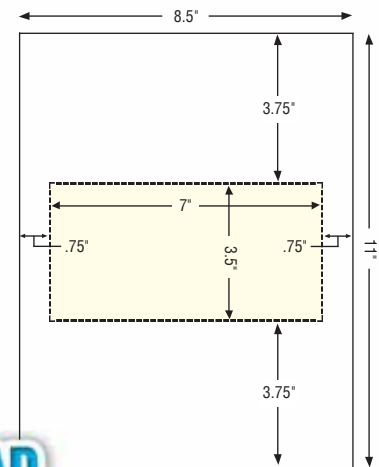

Folder Pockets

**DOWNLOAD
MICROSOFT
TEMPLATES
ONLINE**

Guidelines for Material We Typeset

We will typeset text in 9-point Helvetica type and resize to fit if too long.

- **For back cover:** Submit approximately 1 page of single-spaced, 9 pt. typed text (900 words maximum).
- **For handbook** (area above pockets): For each side, submit approximately ½ page of single-spaced, 9 pt. typed text (450 words maximum).
- **For pockets:** For each side, submit approximately ⅓ page of single-spaced, 9 pt. typed text (300 words maximum).

Ordering Details

Ordering & Payment

- To begin production, we must have a completed and *signed* order form and ALL material, including mascot and any custom material. If material is received after the order is received, the ship date will be adjusted.
- If your school or district requires a purchase order, it is your responsibility to provide it, not School Mate's®.
- Except for orders from schools with APO and FPO addresses, orders outside the USA are not accepted.
- Payment from schools/districts is not due until Sept. 1, 2012. Payment for orders shipped after Sept. 1, 2012 is due upon receipt. We reserve the right to require prepayment. Early invoicing is available. All material must be received to invoice early.

Free Proof

- On the order form, provide a proof contact name, e-mail address, and fax number. If we cannot contact someone to proof your material, production and shipping will be delayed.
- We e-mail a **FREE** proof of any material requiring typesetting or design. This includes front and back covers, pockets, or handbook (area above pockets). Subsequent proofs cost extra.
- Customers who order stock items or submit press-ready material will not receive a proof.
- Proofs are sent 2–3 weeks after we receive your order. You must respond to the proof within 3 business days to avoid production and shipping delays.
- Overlooked errors will be considered customer errors.

Production Time

- Normal Production** is 30 business days (6 weeks) from the day *after* the order is received. See schedule below. Normal ship dates are estimates as seasonal demands, shortages, or any other reasonable causes can affect ship dates.*
- RUSH Production** is 15 business days (3 weeks) from the day *after* the order is received. See schedule below. Rush orders incur a 20% up-charge (**\$75 minimum**). **All material (front and back covers, handbook area, pockets) must be stock items or press-ready, if custom.**
- If Substitute Teacher Folders are ordered separately, they will ship in 5–10 business days. Otherwise, these folders will ship together with your Standard or Handbook Folder order.
- We are not in production on weekends or holidays. Production does NOT include shipping time – see Shipping.
- Changes or corrections to originally submitted material will cause a delay in production and may incur additional charges.

Free Shipping

- Shipping is **FREE** for orders shipped within the continental USA. Orders to APO, FPO, AK, and HI cost extra—call for charges. Faster delivery service is available for an extra charge.
- All orders within the 50 states are shipped by UPS ground or truck from Kearney, NE. APO and FPO orders are shipped Parcel Post. To prevent delays, we reserve the right to not use customer's shipping account or third-party shipping services.
- UPS will deliver to the door only. Truck drivers are not required to give assistance unloading. You may be responsible for unloading.
- Allow 2–8 business days for delivery on orders within the 50 states. For APO and FPO orders, allow 6–12 weeks (USPS does not guarantee a service commitment for APO and FPO addresses).
- Delayed shipping and invoicing are available.

2012 Production Schedule

| Order Received | Normal Ship | Rush Ship | Order Received | Normal Ship | Rush Ship | Order Received | Normal Ship | Rush Ship |
|----------------|-------------|-----------|----------------|-------------|-----------|---|-------------|-----------|
| Feb. 27 | Apr. 9 | Mar. 19 | May 14 | June 26 | June 5 | July 30 | Sept. 11 | Aug. 20 |
| Mar. 5 | Apr. 16 | Mar. 26 | May 21 | July 3 | June 12 | Aug. 6 | Sept. 18 | Aug. 27 |
| Mar. 12 | Apr. 23 | Apr. 2 | May 29 | July 11 | June 19 | Aug. 13 | Sept. 25 | Sept. 4 |
| Mar. 19 | Apr. 30 | Apr. 9 | June 4 | July 17 | June 25 | Aug. 20 | Oct. 2 | Sept. 11 |
| Mar. 26 | May 7 | Apr. 16 | June 11 | July 24 | July 2 | Aug. 27 | Oct. 9 | Sept. 18 |
| Apr. 2 | May 14 | Apr. 23 | June 18 | July 31 | July 10 | Sept. 4 | Oct. 16 | Sept. 25 |
| Apr. 9 | May 21 | Apr. 30 | June 25 | Aug. 7 | July 17 | Sept. 10 | Oct. 22 | Oct. 1 |
| Apr. 16 | May 29 | May 7 | July 2 | Aug. 14 | July 24 | Sept. 17 | Oct. 29 | Oct. 8 |
| Apr. 23 | June 5 | May 14 | July 9 | Aug. 20 | July 30 | Sept. 24 | Nov. 5 | Oct. 15 |
| Apr. 30 | June 12 | May 21 | July 16 | Aug. 27 | Aug. 6 | For orders received before Feb. 27 or after Sept. 24, allow 30 or 15 business days for Normal or Rush production, respectively. | | |
| May 7 | June 19 | May 29 | July 23 | Sept. 4 | Aug. 13 | | | |

*Normal ship dates are estimates only. All ship dates are when orders ship from the School Mate® plant in Kearney, NE. Allow 2–8 business days for delivery time.

Terms & Conditions: These terms supercede any terms and conditions of a purchase order. We do not accept purchase orders without a completed order form. **Payment:** Payment is due Sept. 1, 2012. Payment for orders shipped after Sept. 1, 2012 is due upon receipt. We reserve the right to require prepayment. Accounts 30 days past due will be charged 1.5% interest per month (18% annum) or maximum allowed by law. All prices are based on US currency. All orders are subject to a 5% overrun or underrun. Customer will be invoiced for the number of folders received, not the number ordered. If order is canceled, customer will be liable for any actual costs in preparation or production of the order. **Shipping:** If folders are returned to School Mate® because no one was available to receive the shipment, or if freight is rerouted, the customer is liable for any additional freight charges. We are not responsible for delays in shipping or receipt of order due to strikes, shortages, or any other reasonable causes beyond School Mate's® control. We reserve

the right to deny customer-specified carriers or accounts. **Errors & Defects:** Errors from inadequate proofing or inadequately submitted material are not the fault of School Mate®. Defects in folders not due to shipping damage must be reported to School Mate® within 90 days of ship date. School Mate® reserves the right to repair, replace, or credit defective folders. **Copyright:** The customer warrants that releases have been obtained to reproduce any and all copyrighted or trademarked material submitted for reproduction. The customer shall defend, indemnify, and hold School Mate®, its subsidiaries, and its authorized representatives harmless against all claims, suits, costs, damages, judgments, attorney fees, license fees, settlements, or expenses incurred, claimed, obtained, or sustained by third parties, whether for intellectual property infringement (including copyright and trademark infringement), dilution, misappropriation, or otherwise, because of the manufacture, use, marketing, or sale of folders.



12-13 School Folder Order Form

Signed order form required. Phone orders not accepted. Call 800-516-8339 with questions.
Mail order to: P.O. Box 2110, Kearney, NE 68848 or Fax order to: 800-570-1767
Do NOT fax press-ready material.

For Office Use Only - 1/12
Order # _____
Date Rec'd _____

School Name _____
District Name _____
Contact Name _____ Title _____
School Mailing Address _____
City, State, Zip _____
Ship Address (If different. No PO Boxes) _____
Ship City, State, Zip _____
School Ph (_____) _____ Fax (_____) _____
Home Ph (_____) _____ Cell (_____) _____
E-mail (required) _____

Proof Contact (Provide SUMMER contact info)
Name _____ Fax (_____) _____
Home Ph (_____) _____ Cell (_____) _____
Home E-mail (required) _____
Work E-mail (required) _____
Bill Attention to: _____
 PO# (opt.) _____ Invoice Us
 Pay by Credit Card: To pay by credit card, go to www.schoolmate.com and click on "Pay Online."
Early Invoice by ____/____/____

Signature Required Below

Folder Type: Check only one.

Standard Folder (see p. 2 for description and prices).....Quantity _____ x price/folder \$ _____ = \$ _____
 Handbook Folder (see p. 3 for description and prices; see p. 9 for material).....Quantity _____ x price/folder \$ _____ = \$ _____
Handbook material is: Press-ready (don't fax) Needs to be typeset (enclosed) Repeat last year's handbook w/ no changes.

100 Minimum Order Required

Cover Type/Colors: Complete only one cover selection below.

Full-Color Stock Design
#F _____ (see p. 4-5)
Enclose mascot (optional) or mascot # _____
Complete Cover Wording below for imprint on the cover.
 Repeat last year's front cover design.

One-Color Custom Design (see p. 6)
Specify one ink from p. 6: _____
 Stock One-Color Design #CF _____
Enclose mascot (opt.) or mascot # _____ and complete Cover Wording.
 Our own One-Color Design. Submit material and complete Cover Wording.
 Repeat last year's front cover design.

Two-Color Custom Design (see p. 6)
Specify two inks from p. 6: _____, _____
 Stock Two-Color Design #TF _____
Enclose mascot (opt.) or mascot # _____ and complete Cover Wording.
 Our own Two-Color Design. Submit material and complete Cover Wording.
 Repeat last year's front cover design.

Cover Wording

Wording for Title _____
Additional Wording _____

Back Cover Printing: Check only one. Material not press-ready may incur a charge (see p. 7 and 9).

Stock Design #B _____ Press-ready (don't fax) Needs to be typeset (enclosed) Repeat last year's Blank

Pocket Printing: If press-ready or needs to be typeset, please enclose material and indicate left and right placement (see p. 8-9).

Left Pocket: Stock Design #P _____ Press-ready (don't fax) Needs to be typeset Repeat last year's Blank
Right Pocket: Stock Design #P _____ Press-ready (don't fax) Needs to be typeset Repeat last year's Blank

UV or Lamination: If blank, folders will be UV Coated. UV Coating...FREE Plastic Lamination...20¢/folder \$ _____

3-Hole Drill: No Extra Charge Yes No If no selection is made, folders will NOT be drilled.

ST1 - Substitute Teacher Folder (see p. 5 for description and prices).....Quantity _____ x price/folder \$ _____ = \$ _____
Cannot be customized. Does NOT include UV coating or plastic lamination to allow writing. (25 min.)

Shipping: Shipping is FREE for ground delivery within the continental USA. Call for charges to AK, HI, APO, or FPO. Subtotal \$ _____

Production: We must have a completed and signed order form and ALL material to begin production (see p. 10).
Order will be processed with NORMAL Production, estimated at 30 business days (6 weeks), unless "RUSH Production" is checked below.

RUSH Production - 3 weeks add 20% \$ _____
Custom material must be submitted press-ready. (\$75 min.)

Delay Ship (opt.): Apr 27 June 1 July 6 July 20 July 27
 Aug 3 Aug 10 Aug 17 Aug 24 Aug 31

TOTAL

Order will not be processed without a signature.
Sign Here _____ Date _____
By signing, you agree to School Mate's® Terms & Conditions on p. 10.

Nebraska orders, please provide your Nebraska Exempt Sales Certificate (Form 13) to avoid paying sales tax.

SPECIAL INSTRUCTIONS: If you have special instructions, please attach.

detach here

If no choice is marked, area will be left blank.